



*Coaxial Dynamics*

A CDI INDUSTRIES, INC. COMPANY  
SPECIALISTS IN RF TEST EQUIPMENT & COMPONENTS

6800 Lake Abram Drive  
Middleburg Heights, OH 44130  
Telephone: (440) 243-1100  
Fax: (440) 243-1101  
Web Site: [www.coaxial.com](http://www.coaxial.com)  
E-mail: [support@coaxial.com](mailto:support@coaxial.com)

---

# Instruction Manual

---

## **Model 86552 / 53 / 54 Integrated Coaxial Load And Heat Exchanger**





# INTRODUCTION

This manual gives you specific information on the installation, operation and service Model 86552/53/54/54 Series Integrated Coaxial Load and Heat Exchanger. Most of the loads are field serviceable, but we recommend their return to us for repair. Mistakes can be costly compared to the low cost for our trained personnel to make the repairs and return the load to new performance specifications. Labor and packaging costs are minimal. We take the load completely apart, clean and inspect all parts, repair/replace as necessary, reassemble, water pressure test, power test, VSWR test and package the load for shipment. If new parts are required in the load (such as resistors etc.), this will be an additional cost. The average turn-around time on repairs is approximately 10 working days and generally will depend on your needs. When sending in repairs, please include: your company name and address, the operating frequency you use, fax number, telephone number and your name in case we need to talk to you about the load or obtain shipping instructions. We can accommodate most shipping methods.

SHIP TO:

Coaxial Dynamics  
6800 Lake Abram Drive  
Middleburg Heights, Ohio, USA 44130

For information call:

1-800-COAXIAL (1-800-262-9425)

# TABLE OF CONTENTS

## MODEL 86552/53/54/54

<u>SECTION</u>	<u>PAGE</u>
Introduction.....	2
Warning.....	5
Precautions.....	6,7
I. Description and Leading Particulars	
1-1 Purpose and Application of Equipment.....	8
1-2 Equipment Supplied .....	8
1-3 Equipment Required But Not Supplied.....	8
1-4 General Description.....	8
1-5 Electrical Description .....	8,9
1-6 Mechanical Description.....	9
1-7 General Principle.....	9
1-8 Interlock Controls and Operation.....	9
1-9 Operating and Adjustment Controls.....	9
II. Test Equipment and Special Tools	
2-1 Test Equipment Required.....	10
2-2 Special Tools Required.....	10
III. Preparation for Use and Reshipment	
3-1 Unpacking.....	11
3-2 Visual Inspection.....	11
3-3 Pre-installation Tests .....	11
3-4 Coolant .....	11,12
3-5 Installation.....	12
3-6 Location.....	12
3-7 Mounting.....	12
3-8 Connections.....	12,13
3-9 Ducting.....	13
3-10 Adjustments.....	13
3-11 Preparation for Reshipment.....	13
IV. Operation	
4-1 Overview .....	14
4-2 Control Circuits .....	14
4-3 To Begin Operation .....	14
4-4 To Shutdown.....	14
4-5 Performance.....	14

# TABLE OF CONTENTS (cont'd)

## MODEL 86552/53/54/54

<u>SECTION</u>	<u>PAGE</u>
V. Maintenance	
5-1 Cleaning.....	15
5-2 Lubrication .....	15
5-3 Periodic Maintenance .....	15
5-4 Routine Service Checks.....	15
VI. Calorimetry	
6-1 General .....	16
6-2 Calorimetry Theory .....	16
6-3 Practical Calorimetry.....	16-17
K <sub>t</sub> Graph.....	17
Coolant Density/Flow Meter Correction .....	18
VII. Repair Procedures	
7-1 Overview .....	19
7-2 Resistor Replacement .....	19
7-3 Water Jacket Replacement.....	19
7-4 Other Repairs.....	19
VII. Diagrams and Illustrations	
Model 86552/53/54/54 Heat Exchanger Load 50KW .....	cover
K <sub>t</sub> Graph.....	17
Coolant Density/Flow Meter Correction .....	18
Schematic Diagrams .....	20
Replacement Parts List .....	21
Specifications.....	22
Appendix A	
Component Manufacturer's Documents.....	23-26

## **!! WARNING !!**

**DO NOT OPERATE PUMP UNTIL YOU HAVE  
DETERMINED THAT THE DIRECTION OF  
ROTATION IS CORRECT!**

***TO DO SO CAN CAUSE DAMAGE TO THE PUMP!***

**FOLLOW THE PROCEDURE BELOW TO DETERMINE THAT YOU HAVE  
CONNECTED THIS DEVICE CORRECTLY TO THE AC MAINS:**

- 1. CONNECT 3-PHASE AC MAINS POWER.**
- 2. DEPRESS THE BLACK BUTTON IN THE CENTER OF THE FAN CONTACTOR, WHICH IS ON THE RIGHT IN THE WIRING CHANNEL.**
- 3. HOLD THIS BUTTON IN FOR 30 SECONDS.**
- 4. DETERMINE IF AIR IS FLOWING FROM THE REAR OF THE DEVICE, INDICATING THAT THE FAN IS ROTATING PROPERLY.**
- 5. IF THERE IS NO AIRFLOW, THE FAN IS OPERATING IN REVERSE. EXCHANGE 2 LEADS OF THE AC MAINS AND TEST AGAIN.**
- 6. YOU MAY NOW PROCEED WITH INSTALLATION AND OPERATION OF THE UNIT.**

# PRECAUTIONS

## CAUTION

Do not block air grills; blocking air flow can cause unit to fail!

## !!!WARNING!!!

Do not apply any RF power to the unit before transmitter interlock is connected and operational. Failure to do so may result in damage to equipment and/or injury to personnel.

## CAUTION

Do not operate Heat Exchanger Load without connecting interlock!!! Application of RF even momentarily if unit is off or coolant flow is restricted will destroy the resistor element!!!

## ⚡WARNING⚡

Do not attempt any service or parts replacement without first disconnecting all AC power and RF power. Failure to do so may result in serious or *fatal electrical shock*.

## CAUTION

Do not apply more than rated power to unit. Damage will occur before thermal protectors can activate interlock circuit if more than rated power is applied.

## CAUTION

Do not use any stop leak, sealants, automotive antifreeze or Union Carbide Ucartherm™ in coolant.  
Use only pure ethylene glycol and potable water!!!!

## CAUTION

Do not operate pump with coolant low or empty.  
To do so will result in damage to working parts and seals.

# PRECAUTIONS

## CAUTION

Operation above rated ambient temperature may result in motor thermal protection shutting off fan which may cause damage to unit. Provisions are made to trip interlock in the event of overheat; however care should be taken to operate the unit below stated maximum operating ambient temperature.

## NOTICE

Failure of unit due to accumulation of solids in water will void the warranty.

## CAUTION

HEAT EXCHANGER IS DIFFICULT TO DRAIN COMPLETELY! IF UNIT IS DRAINED TO PROTECT FROM FREEZE DAMAGE, IT IS NECESSARY TO USE A WET/DRY VACUUM TO PULL WATER FROM DRAINS OR TO USE COMPRESSED AIR TO BLOW OUT RESIDUAL WATER. FREEZE DAMAGE TO COILS OR OTHER COMPONENTS MAY RESULT FROM FAILURE TO DRAIN COMPLETELY.

## ☠WARNING☠

ETHYLENE GLYCOL IS A TOXIC SUBSTANCE THAT MAY CAUSE PERMANENT DAMAGE TO THE SKIN, KIDNEYS, LIVER AND OTHER ORGANS. AVOID CONTACT WITH SKIN. AVOID BREATHING VAPORS. SEE THE MATERIAL SAFETY DATA SHEET FOR THE SPECIFIC PRECAUTIONS AND FIRST AID MEASURES PRESCRIBED BY THE MANUFACTURER.



# SECTION I

## DESCRIPTION AND LEADING PARTICULARS

**1-1. Purpose and Application of Equipment.** The Model 86552/53/54 Coaxial Load is designed to safely dissipate a maximum of 50,000 watts of electrical energy over a frequency range of 60 Hz to 800 MHz.

**1-2. Equipment Supplied.** The Model 86552/53/54 Coaxial Load is supplied with standard RF connectors. Their designations are:

3 1/8 EIA Swivel flange:	.....	Model 86552-1
3 1/8 Unflanged recessed:	.....	Model 86552-2
3 1/8 Unflanged flush:	.....	Model 86552-3
6 1/8 EIA Fixed flange:	.....	Model 86553-1
4 1/16 EIA Fixed flange:	.....	Model 86554-1

The standard 50/60 Hz power supply voltage and its designation is:

-230: 220-240VAC single phase

**1-3. Equipment Required But Not Supplied.** The Model 86552/53/54 Coaxial Load is complete as supplied, but the user must furnish RF input, interlock control cable, power supply cable, ground cable and proper coolant. Where the purchaser specifies that the coaxial load be remotely mounted, it will be necessary for the user to supply suitable piping or hoses to connect the load to the heat exchanger.

**1-4. General Description.** The Model 86552/53/54 Coaxial Load is an assembly of a Model 86052/54 RF Coaxial Load and a heat exchanger assembly. The heat exchanger is essentially a reservoir, a pump and a radiator intended to dissipate the heat produced by the load. The complete Model 86552/53/54 is normally enclosed in a single aluminum case, but the purchaser may specify remote mounting for the load to facilitate installation. AC mains power connection is made through a NEMA locking-type receptacle mounted on the left side panel. This panel also contains a 4-screw barrier terminal strip for connection of the interlock circuit. The main chassis frame contains a pump, fan, flow switch, time delay relay, reservoir, heat exchanger coil and associated controls.

**1-5. Electrical Description.** The Model 86552/53/54 includes a 50 ohm non-reactive resistor assembly capable of dissipating 50,000 watts of applied electrical energy at frequencies between 60 Hz and 800 MHz with a maximum VSWR of 1.1 to 1 to 800 MHz. No provisions are made for tuning the resistor assembly. Power to the blower and pump is controlled by a single On/Off switch (located on the front panel along with fan condition indicator, low coolant indicator, low flow indicator, and overheat indicator lamps).

# SECTION I

## DESCRIPTION AND LEADING PARTICULARS (cont'd)

The transmitter interlock circuit consists of flow switch, delay relay and thermal switch wired in series to control the interlock relay. Power is supplied to this relay whenever the equipment is attached to the correct power supply, neither the overtemperature thermal switch (170°F) or flow switch senses a fault and the time delay relay is activated (approx. 10 seconds after the flow switch has closed).

Lamps are provided to indicate when one or more of these switches is open. One is labeled **OVERHEAT** and indicates any change in state of the interlock circuit. The other is labeled **LOW FLOW** and indicates closure of the flow switch.

### NOTE:

1. Both lamps will be illuminated briefly when the pump is started.
2. Both lamps will illuminate when coolant flow is below minimum.
3. Only the OVERHEAT lamp will illuminate when an overheat condition occurs and flow is adequate.

**1-6. Mechanical Description.** The Model 86552/53/54 RF Coaxial Load is a Model 86052/54 50 ohm resistor assembly cooled by a vented, closed-loop water system, utilizing a centrifugal pump, water-to-air heat exchanger (capacity of coolant is approximately 11 U.S. Gal.), and 1 centrifugal blower. The blower assembly is a 1.5 HP belt-driven centrifugal blower. The blower moves air into a closed plenum, through the heat exchanger coil to the rear of unit.

**1-7. General Principle of Operation.** After ascertaining that the Model 86552/53/54 is connected to the correct power supply and filled with coolant, connect the transmitter interlock circuit and RF source. Turn the main power switch ON to start operation and enable transmitter. Operate transmitter as desired.

To stop operation, it is necessary to first turn off the transmitter, then wait five minutes before turning off the power switch on the load. It is important that the unit cools down and temperatures stabilize before fan and pump operation stops.

**1-8. Interlock Controls and Operation.** A 4-screw barrier terminal strip is provided on the left side panel for transmitter interlock. This terminal provides two normally closed pairs.

**1-9. Operating and Adjustment Controls.** The only operating control is the main power switch. No field adjustments are necessary or possible.

# SECTION II

## TEST EQUIPMENT AND SPECIAL TOOLS

2-1. **Test Equipment Required.** No test equipment is required for routine maintenance, however it may be necessary to verify DC resistance of the coaxial resistor and/or verify coolant temperature, in which case you will need an accurate digital ohm-meter and precision thermometer.

2-2. **Special Tools Required.** Although no non-standard tools are required for routine maintenance, we recommend the technician have the following specialized tools available:

- 1 Tee handle hex key, 5/32 inch
- 1 Tee handle hex key, 3/32 inch
- 1 Tee handle hex key, 3/16 inch
- 1 Power screwdriver with torx T-15 bit
- 1 Torx T-15 screwdriver
- 1 Hydrometer (Range 1.000 to 1.070)
- 1 pH Test Kit (Range 7.0 to 8.2)

# SECTION III

## PREPARATION FOR USE AND RESHIPMENT

- 3-1. Unpacking.** The unit should be handled and unpacked with care. Inspect outer carton for evidence of damage during shipment. *Claims for damage in shipment must be filed promptly with the transportation company involved.* No internal packaging or bracing is used for domestic shipments and the unit should not rattle when being unpacked.
- 3-2. Visual Inspection.** Conduct a thorough inspection of the unit, paying particular attention to the following items:
- Screws in place and tight.
  - All panels and grills free of dents and scratches.
  - Interlock terminal strip visually OK.
  - RF connector visually OK. While inspecting RF connector, measure D.C. resistance of the unit by reading from the center conductor to the outer conductor. It should be 50 ohms (nominal).
- 3-3. Pre-installation Tests.** Prior to installation, fill unit with specified coolant (see para. 3-4), then connect unit to a suitable source of AC power. Turn main switch on and check for quiet blower operation. Connect an ohmmeter or a battery operated test lamp across the normally closed terminal pair on the interlock terminal board (rear panel). Turn the main power switch off observing the indicator (ohmmeter or test lamp). It should change state (terminals open).
- 3-4. Coolant.** The coolant should be potable water if the ambient temperature will not drop below +5°C (40°F). The U.S. Department of Public Health has set the standard for potable water at a maximum of 500ppm of total dissolved solids. The water hardness (content of calcium, lime and magnesium salts) should be less than 75ppm. These conditions can be achieved by mixing with distilled water. Acidic coolant solutions will cause early failure of the resistor, so the pH should be checked to insure values between 6.8 and 7.8.

*SUGGESTION:* If your municipal water has unpleasant tastes or odors, high salt or mineral levels (hardness, iron, sulfides, etc.), we suggest that you purchase bottled water (often sold as "spring water") for use in the load. It is very inexpensive insurance. If ambient temperatures are expected to fall below +5°C (40°F), a mixture of inhibited technical grade ethylene glycol and potable water may be used (with a 20% de-rating of unit to 40KW at some temperatures). See Specifications.

To fill unit, first connect unit to AC power, then fill reservoir with coolant. Turn unit on to pull coolant into circuit and add coolant again until LOW COOLANT light goes out. Continue adding coolant to bring level to 2 inches below filler neck top. Capacity of unit is approximately 11 U.S. Gallons (41.6 liters).

# SECTION III

## PREPARATION FOR USE AND RESHIPMENT (cont'd)

**!!!CHECK FOR LEAKS FROM DRAIN PLUGS  
AND RESERVOIR DRAIN AT THIS TIME!!!**

### **CAUTION**

**Do not use any stop leak, sealants, automotive antifreeze  
or Union Carbide Ucartherm™ in coolant.  
Use only pure ethylene glycol and potable water!!!!**

**3-5. Installation.** Consideration must be given to accessibility for maintenance and unit replacement. No attempt is made in this handbook to present complete installation instructions, since physical differences in plant will determine the installation procedure. General guidelines are outlined in subsequent paragraphs.

**3-6. Location.** The location selected for the Model 86552/53/54 should be dry, free of excessive dust and have an ambient temperature between +5°C and 35°C (41°F and 95°F) with water only, and -20°C and +30°C (-4°F and 86°F) with ≤35% ethylene glycol mixture. The room should be well ventilated to prevent excessive heat build-up.

The RF dissipation of the unit is 50,000 watts. This equals 170,650 Btu/hr which ordinarily must be ducted out of the building envelope, using as short and direct duct run as is possible to minimize static pressure and to prevent loss of cooling efficiency. The assistance of a competent heating and air conditioning installer will help avoid over-or-under specifying the duct system.

**3-7. Mounting.** It is not necessary to mount the Model 86552/53/54, which is designed to be a free-standing device. It rests on four heavy duty casters. Brakes are installed on the swivel casters to stabilize the unit during operation.

**3-8. Connections.** There are three connectors on the Model 86552/53/54: the RF connector, the AC power connector and the transmitter interlock (4 terminal, captive-screw terminal strip).

- a. The RF connector is on the coaxial load, which is normally attached to the right side panel of the unit. Connect to the appropriate RF line from the transmitter.
- b. The AC power connector is a pressure-terminal connector strip within the cabinet. Cordage for this application should be carefully selected to meet the ampacity requirements of the unit.
- c. The transmitter interlock is attached to the normally closed terminals of the terminal board on the left side of the unit. The terminals close approximately 10 seconds after the power switch is on and the unit is operating properly. The normally open pair is isolated from the normally closed pair and is provided for an alarm circuit.

# SECTION III

## PREPARATION FOR USE AND RESHIPMENT (cont'd)

### **CAUTION!**

**The unit should be attached to the proper AC power supply with interlock connected whenever the RF connector is attached to the source. Inadvertent application of RF power to the unit without AC power will damage or destroy the resistor assembly!!!**

- 3-9. Ducting.** In many installations it will be necessary to duct the discharge air from the Model 86552/53/54 to the exterior of the building. In some installations it will also be necessary to supply inlet air from outside of the climate controlled portion of the building. The discharge air flow is approximately 1500 SCFM at a maximum temperature of 160°F. Due to the high temperatures involved, non-metallic duct materials should not be used. Make-up air is a ventilation term used to indicate the supply of outdoor replacement air to a building in a controlled manner. Replacement air will enter the building to equal the volume actually exhausted, whether or not provision is made for this replacement. It is important to plan for make-up air of the proper temperature and volume.
- 3-10. Adjustments.** No field adjustments are necessary or possible.
- 3-11. Preparation for Reshipment.** If unit is to be shipped by air freight or through an area where it is possible it will be exposed to freezing temperatures, it is imperative to prepare it properly for shipment. NOTE: Drains are incorporated into plumbing to allow easy drainage of unit. There are three small drains with brass caps under the unit on the front near the center. There is a drain valve located near these drains. It drains the reservoir and part of the system. The drain valve is fitted for a 3/4 inch garden hose. Drain the coolant from the unit (the use of a wet vacuum cleaner is very helpful to prevent spillage) prior to shipment. After coolant is completely drained, add three gallons of inhibited technical grade ethylene glycol or DOWTHERM SR-1® coolant to the reservoir. Start the pump and circulate this fluid thoroughly throughout the system. Now drain the unit of all free-flowing liquid and close all drain valves. Fluid which is trapped in the system will not freeze and damage the unit. Care must be taken to protect the RF connector and to immobilize the swivel flange, if it is fitted with one. It is suggested that you retain the original shipping crate to provide the optimum protection during reshipment.

# SECTION IV

## OPERATION

- 4-1. Overview.** The Model 86552/53/54 incorporates a Model 86052/54 Coaxial Resistor which dissipates RF energy by converting it to heat that is dissipated into the air via a vented, closed-loop water-to-air heat exchanger. This self-contained water system allows for the use of a water-cooled load, providing the best possible RF Load in areas that do not have suitable water supplies. Where water temperatures less than +5°C could be encountered, a solution of ≤35% technical grade ethylene glycol may be used as coolant (*automotive antifreeze or Union Carbide Ucartherm™ must not be used*). Use of ethylene glycol mixture derates unit 20% to 40kW.
- 4-2. Control Circuits.** There are 2 control circuits in the Model 86552/53/54. One circuit controls the blower and pump, the other controls the transmitter interlock circuit. The interlock circuit is controlled by a flow switch (detects adequate water flow) connected in series with a time delay relay that allows a short period of time after the water is flowing before energizing the interlock. This series circuit also contains the overtemperature thermal switch, which is mounted on the reservoir. The blower is controlled by the main power switch. The pump is turned on by the main power switch. The Low Coolant Lamp is controlled by a float in the reservoir and is for indication only. It is not connected to the interlock.
- 4-3. To Begin Operation.** After following installation instructions, turn main power switch to *ON*. Initially, the *LOW FLOW* and *OVERHEAT* lamps will illuminate. The *LOW FLOW* lamp will extinguish, followed by the *OVERHEAT* lamp about 10 seconds later. Unit is now ready for operation. (The transmitter interlock will normally close approximately 10 seconds after the unit is turned on. Delays greater than 15 seconds may indicate marginal flow and should be investigated.
- 4-4. To Shutdown.** *WARNING! Transmitter must be turned off prior to shutting down LOAD to prevent damage to load resistor.* After RF power has been turned off, *WAIT 5 MINUTES* before turning off load to allow heat in the unit to be stabilized and dissipated. Transmitter interlock will open when unit is turned OFF.
- 4-5. Performance.** The Model 86552/53/54 will handle 50KW continuously at a maximum ambient temperature of 35°C using pure potable water. See SPECIFICATIONS for other conditions. Thermal performance is affected by impurities and chemicals in the coolant. Therefore, only potable water or an approved strength mixture of technically pure ethylene glycol and potable water should be used as a coolant. Accumulations of scale and other contaminants will greatly reduce the thermal efficiency and cause the unit to overheat and fail.

# SECTION V

## MAINTENANCE

### **WARNING!!**

#### **BEFORE PERFORMING ANY MAINTENANCE:**

1. **DISCONNECT POWER AND ALLOW MOTOR TO COME TO A FULL STOP.**
2. **DISCONNECT RF CONNECTOR ASSEMBLY AND LOCK OUT TRANSMITTER OPERATING CONTROLS.**
3. **DISCONNECT TRANSMITTER LINE.**

***FAILURE TO FOLLOW THESE DIRECTIONS  
MAY CAUSE FATAL ELECTRICAL SHOCK!***

**5-1. Cleaning.** The enclosure of the Model 86552/53/54 is finished with a durable coating system. It should be cleaned with a neutral plastic and glass cleaner such as Miller-Stephenson MS-260. The RF connector should be cleaned with a non-residue contact cleaner such as Miller-Stephenson MS-230. Remove dirt accumulations from the fan and motor by vacuuming. Do not use solvents or an air jet, as these can damage the motor. Remove dirt and dust accumulations from the grills and resistor assembly with an air jet and a soft brush. This should be done annually or more often if in a dirty environment.

**5-2. Lubrication.** The only lubrication required is for the bearings in the blower motor. Units in continuous service should be re-oiled annually, intermittent duty units every two years and occasional duty units every three years. Re-oil by removing the plastic plugs in the lubrication ports and applying 30 to 35 drops of SAE 20 motor oil. **DO NOT OVER OIL.**

**5-3. Periodic Maintenance.** The RF Load Resistor does not require any periodic maintenance, however a DC resistance check prior to each use is recommended. Repair to resistor unit is covered in Section VII.

**5-4. Routine Service Checks.** Check coolant level weekly if used intermittently, more frequently if used continuously. If ethylene glycol mixture is used as coolant, the mixture must be periodically verified using a precision hydrometer (range 1.000 to 1.070) or other suitable instrument to prevent the ethylene glycol from becoming too concentrated. A mixture more concentrated than 35% will lower the efficiency of the unit possibly causing a failure. An acidic condition will cause rapid failure of the resistor. Maintain pH at 6.8-7.8.

**WARNING!: USE OF ANYTHING OTHER THAN PURE POTABLE WATER OR A MIXTURE OF TECHNICAL ETHYLENE GLYCOL AND POTABLE WATER, OR USE OF A MIXTURE MORE CONCENTRATED THAN 35% ETHYLENE GLYCOL WILL VOID THE WARRANTY!!!**

**NOTE: BUILD-UP OF LINT AND DUST ON COILS GREATLY DECREASES THE EFFICIENCY OF THE UNIT. KEEP THEM CLEAN!**

Check for lint and dust build-up on the inside of the cooling coil annually by removing the right hand panel. This is accomplished by removing the 20 #8-32 screws around the edge of the panel. This should be done annually or more often if in a dirty environment.



# SECTION VI

## CALORIMETRY

- 6-1. General.** Physicists have long known that it takes a definite amount of energy in the form of heat to raise the temperature of a certain mass of liquid and conversely, if you know the temperature rise and the mass of the liquid, you can determine the amount of heat and therefore, the amount of energy applied to the liquid. There are many variables in this equation. Among them are: specific heat of the fluid, specific gravity of the fluid, density of the fluid, thermometer accuracy and flow meter accuracy. These factors must be determined or minimized to yield accurate power measurements. The Power Test Load System is designed to provide the user with data which can be reduced to an accurate transmitted power measurement.
- 6-2. Calorimetry Theory.** Since we know from physics that we can determine energy put into a system by measuring temperature and flow rate, we have only to adjust our readings to account for variance from classic values in order to accurately determine transmitter power. The theory of RF calorimetry requires a liquid-cooled coaxial load of low VSWR, accurate thermometry and accurate flow measurement. Data from the thermometers is used to obtain the specific heat, specific gravity and density of the fluid. This information is used to obtain coolant and flow meter factors for use in calculating power values.

Some of the terms we use:

- **Specific heat ( $C_p$ ):** The number of calories required to raise 1 gram of a substance 1 °K.
  - **Specific gravity ( $G$ ):** A ratio of the mass per unit volume at a known temperature to the mass per unit volume of pure water at the same temperature.
  - **Density:** The mass per unit volume of a substance at a certain temperature.
- 6-3. Practical Calorimetry.** Practical calorimetry with the Power Test Load System can be reduced to a systematic process requiring no technical skills beyond the ability to read instruments, use graphs and tables and calculate final values (a handheld calculator helps with the multiplication).

First, a warning! If you don't know what the fluid is, you'll never get a correct answer!

If your system uses "pure" water, i.e. tap water, distilled water, deionized water, etc., you know what the fluid is accurately enough for calorimetry. If your coolant is a mixture of water and ethylene glycol, you cannot be certain what your fluid is until you obtain the specific gravity of your fluid (corrected for temperature) with a laboratory grade hydrometer. Water evaporates from your coolant system, but ethylene glycol doesn't. Therefore, glycol concentrations vary almost daily in an operating system. In systems where fluid loss is made up with water/glycol mixtures, the concentration of glycol gradually increases. Be sure that you know what the specific gravity of your coolant is before you start! Use this value and the Ethylene Glycol Solution Densities chart to determine the percentage of ethylene glycol in your system. The percentage value is used in the calorimetry process.

To accurately determine the transmitted power going to the load:

1. Add clean water to each thermowell until water flows out of the small hole near the base of the column.

# SECTION VI

## CALORIMETRY (CONT'D)

2. Turn on coolant flow and ensure that it is above the minimum value for your system.
3. After 2 to 3 minutes of transmitter operation, you may begin reading instruments.
4. Read flow meter and record observed ("gauge") value.
5. Read inlet fluid temperature and record this value.
6. Read outlet fluid temperature and record this value. Take this reading immediately after reading inlet water temperature.
7. Find the average value of the temperature readings recorded.  $(Temp_{in} + Temp_{out} / 2)$
8. Use the average temperature from (7.) to determine  $K_t$  from the  $K_t$  Graph.
9. Use the outlet fluid temperature determined in (6.) to determine flow meter correction factor from the Coolant Density/Flow Meter Correction nomograph.
10. The equation used to solve the power problem:

$$P = K_t \times (T_{outlet} - T_{inlet}) \times Q \times F$$

Where: P = Power in kilowatts

$K_t$  = Coolant correction factor

$T_{outlet}$  is expressed in °C.

$T_{inlet}$  is expressed in °C.

Q = Coolant flow in gallons per minute

F = Flow Meter Correction Factor

With the data obtained from earlier steps, you should be able to determine the transmitted power within  $\pm 3\%$ .

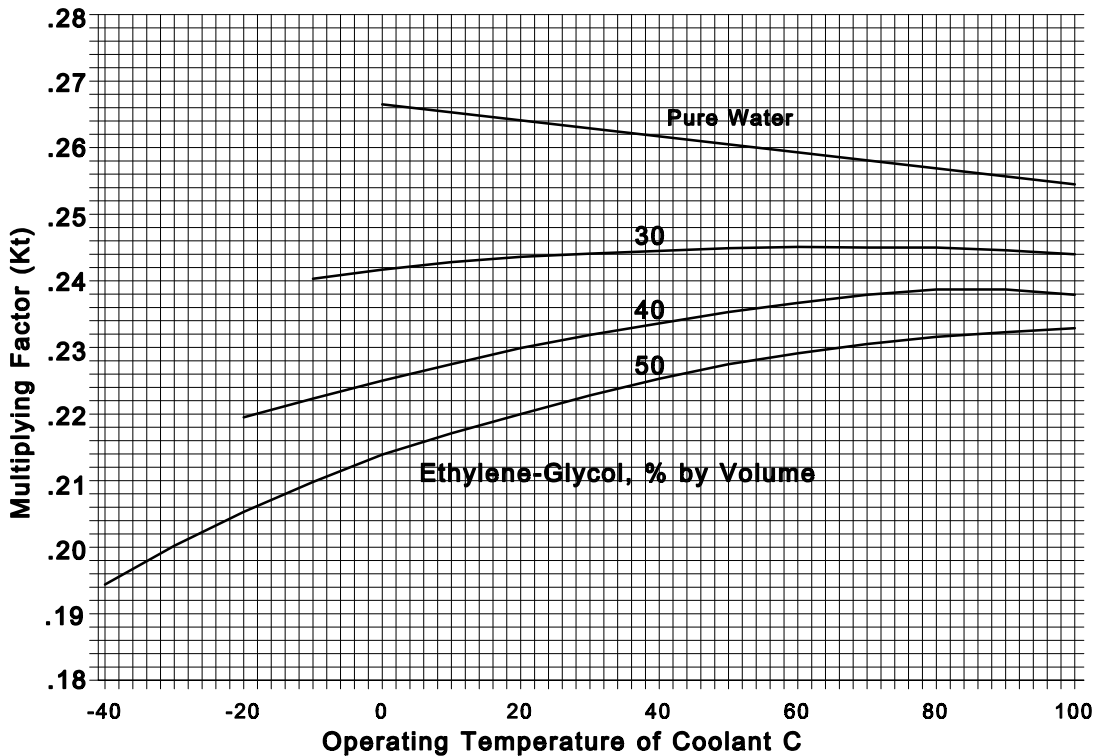

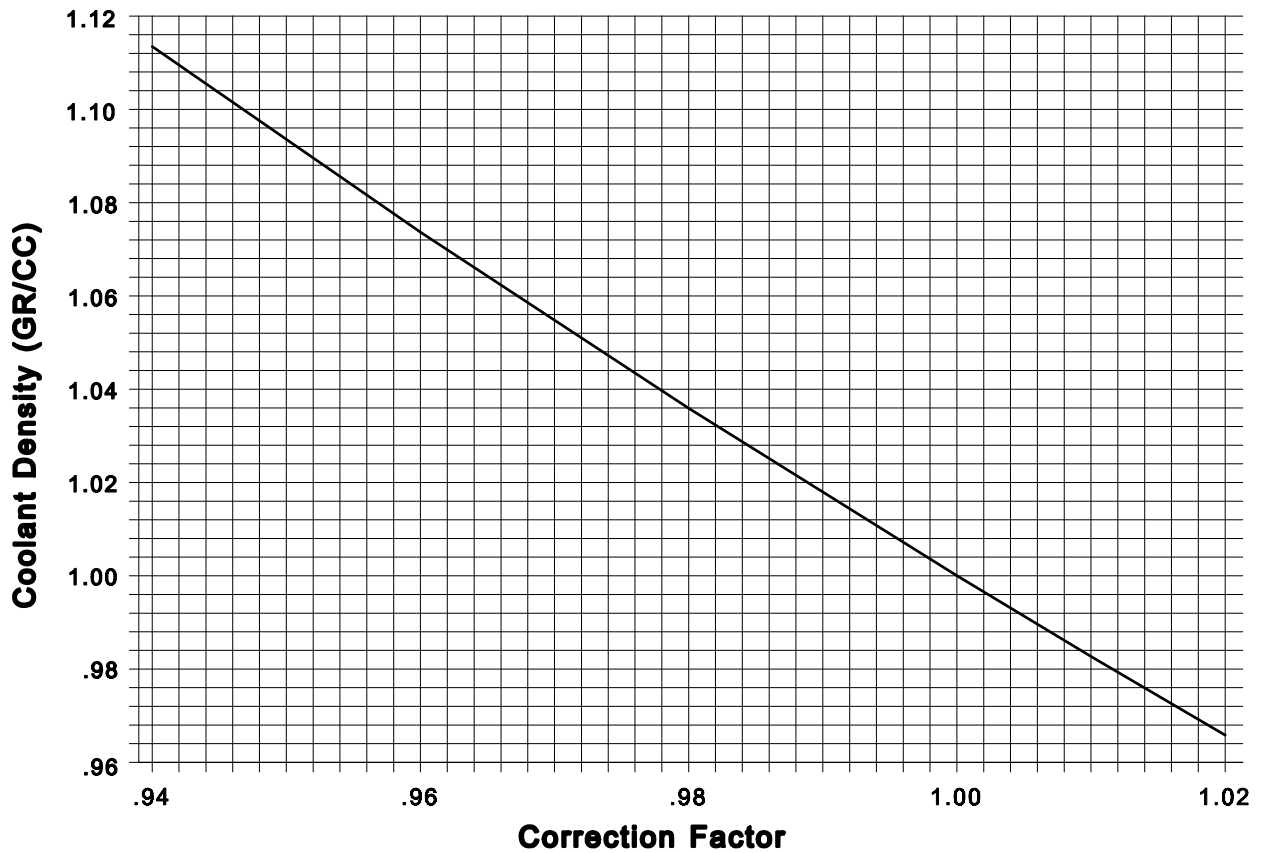
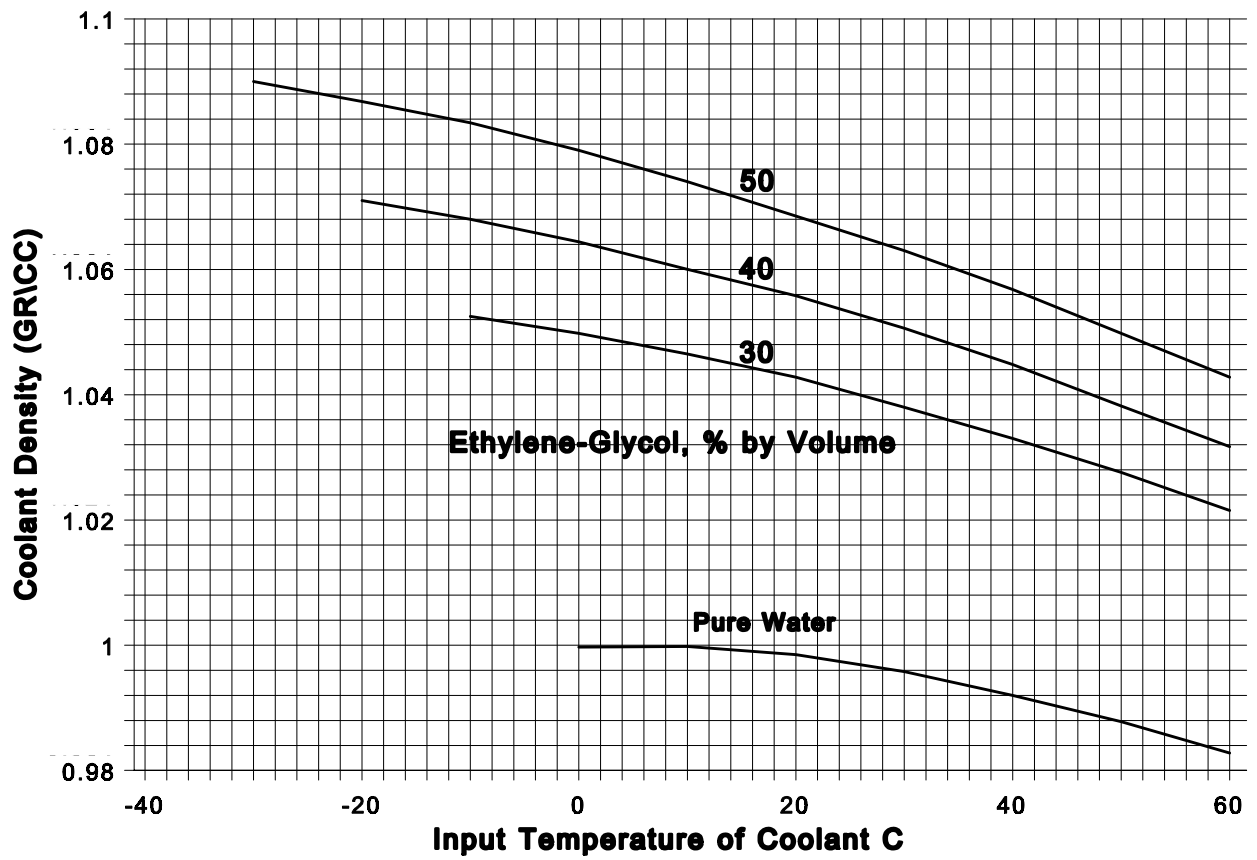

# SECTION VII

## REPAIR PROCEDURES

- 7-1. **Overview.** The Model 86052/54 Coaxial Load Resistor is basically a termination type unit, having its characteristic impedance at the input end and tapered to zero impedance (short circuit) at the other end. The center conductor is a tubular resistor whose DC resistance is equal to the characteristic impedance of the line. The outer conductor of the coaxial line is a symmetrical horn-shaped enclosure, contoured in a semi-logarithmic taper to obtain practically a reflection-free termination. The RF dielectric medium consists of three distinct materials: the coolant, the teflon or noryl water jacket, and the air space. The housing is constructed of aluminum and bronze or brass. Coolant enters the load at the electrically shorted end, flows axially down the center of the resistor tube, mushrooms over into the annular channel under the water jacket, and makes a second pass over the resistor in direct contact with the resistive film. Thus the coolant makes intimate contact with both the inside and the outside of the resistor, providing optimum heat transfer with minimum coolant flow.
- 7-2. **Resistor Replacement.** Follow directions in the instruction manual which pertain to the 86052/54.
- 7-3. **Water Jacket Replacement.** Follow directions in the instruction manual which pertain to the 86052/54.

**SPECIAL NOTE:** After maintenance has been performed on cooling circuit (including resistor replacement), or when there is reason to suspect that the coolant is contaminated, the cooling circuit should be thoroughly flushed with clean water. This should be done by filling the system with clean water and running a short time, then draining and cleaning filter screen. This should be done several times until water is completely clear and filter remains clear of particles. Then refill system with required amount of potable water or approved ethylene glycol mixture.

- 7-4. **Other Repairs.** Normal electrical and mechanical skills are required for repair and replacement of pump and fan assembly.

# SCHEMATIC DIAGRAMS

NO FAULT: 1&2 CLOSED, 3&4 CLOSED  
 FAULT: 1&2 OPEN, 3&4 OPEN  
 1&2: ISOLATED PAIR  
 3&4: ISOLATED PAIR  
 RATINGS: 1A 30VDC/120VAC  
 RESISTIVE

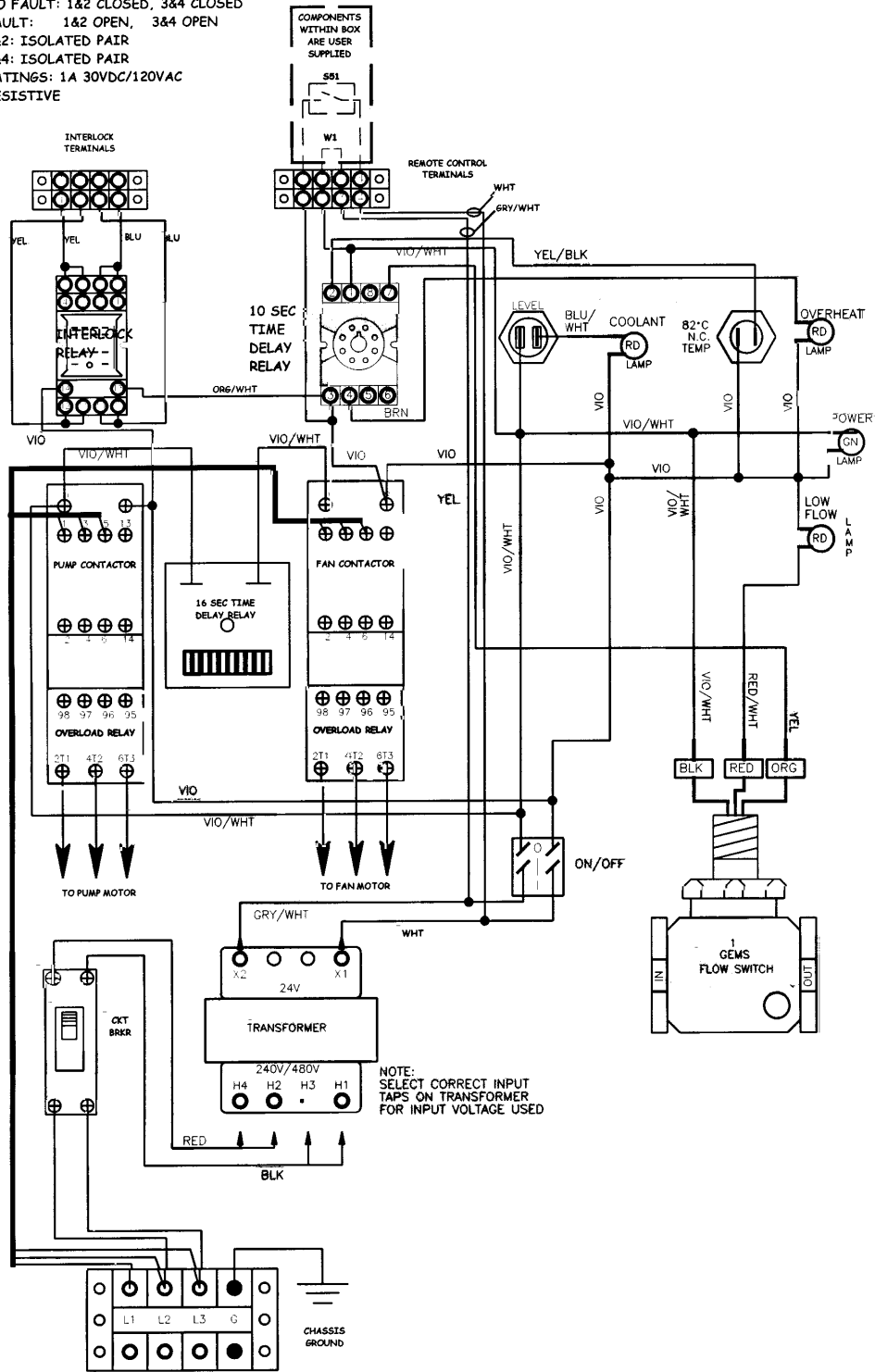

# REPLACEMENT PARTS LIST

## Model 86552/53/54

<u>Item</u>	<u>Qty.</u>	<u>Description</u>	<u>P/N</u>
<i>Heat Exchanger (208-230 VAC)</i>			
1	1	Reservoir Assy	000-05850-010
2	1	Relay Socket Interlock	304-10000-000
3	1	Relay, Time	304-10000-029
4	1	Block, Distribution (4 Pin)	304-10000-051
5	1	Green Lamp	304-10000-116
6	3	Red Lamp	304-10000-117
7	1	Relay, Interlock	339-10000-001
8	1	Spring, Interlock	339-10000-005
9	1	Switch, On/Off	339-10000-041
10	1	Coil	419-05850-001
11	1	Filter Neck/Breather Flow	464-10000-001
12	1	Switch, Thermal	566-10000-127
13	1	Switch, Level	578-10000-126
<i>Plumbing</i>			
14	1	Switch, Flow	426-FS200-MED
<i>Power Set (230 VAC, 50 Hz, 1 Phase)</i>			

# SPECIFICATIONS: Model 86552/53/54

Impedance ----- > 50 ohms nominal  
Frequency Range ----- > 50 Hz to 800 MHz  
VSWR = 60 Hz to 800 MHz ----- > 1.1:1 max.

## Connectors:

Model 86552-1 ----- > 3 1/8 EIA swivel flange  
Model 86552-2 ----- > 3 1/8 unflanged recessed  
Model 86552-3 ----- > 3 1/8 unflanged flush  
Model 86553-1 ----- > 6 1/8 EIA fixed flange

Cooling Method ----- > Air over Water-Heat Exchanger  
Coolant Liquid Capacity ----- > Approximately 44 qts. (41.64 liters)  
Coolant Type ----- > Potable water or 35% ethylene glycol mixture

Power Rating ----- > 50 KW Cont.

## Ambient Temperature vs. Power Ratings:

### 50KW continuous:

Potable water only ----- > +5°C to +35°C (41°F to 95°F)  
35% Ethylene Glycol ----- > -20°C to +30°C (-4°F to +86°F)

### 40KW continuous:

Potable water only ----- > +5°C to +45°C (41°F to 110°F)  
35% Ethylene Glycol ----- > -20°C to +35°C (-4°F to +95°F)

Fan Assembly ----- > 1.5 HP Centrifugal  
Pump ----- > 1.5 HP Centrifugal

## AC Power Requirements:

230 VAC, Single Phase ----- > 27.5 Amp.  
208-230/460 VAC, Three Phase ----- > 9.6/4.8 Amp.

Finish ----- > Beige Splatter

Serial No. \_\_\_\_\_ Frequency \_\_\_\_\_ Resistance \_\_\_\_\_

Model \_\_\_\_\_ Inspected by \_\_\_\_\_ Date \_\_\_\_\_

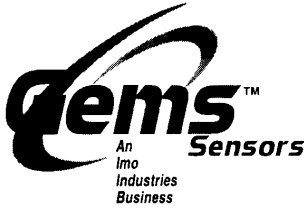

# Shuttle-Type Flow Switches

## Series FS-200/400

Instruction Bulletin No. 45523

### Installation

Install FS-200 or FS-400 Series units in piping system using standard pipe fitting procedures. Be careful to keep sealing compound out of the unit. Be sure to observe direction of flow - marked "IN" and "OUT" on housing. See chart below for port and wrench hex. sizes.

Unless otherwise specified, standard FS-200 and FS-400 units are factory-calibrated with water. FS-200 and FS-200 Adjustable units are installed horizontally, in line, with lead wires up. FS-400 and FS-400 Adjustable units are installed vertically; lead wires up, as shown. 150 micron filtration is suggested for use with all units.

### Specifications (FS-200 Series)

#### Wetted Materials

Housing	
FS-200	Bronze or 316 Stainless Steel
FS-200 Adj.	Bronze
Shuttle	Teflon®
Bonnet	Bronze or Stainless Steel
Spring	316 Stainless Steel
Other Wetted Parts	Viton®, Ceramic

#### Pressure Rating

Operating	400 PSIG @ 100°F (37.8°C)
Proof	800 PSIG @ 100°F (37.8°C)

#### Operating Temperature

FS-200	-20°F to +300°F (-29°C to +148.9°C)
FS-200 Adj.	-20°F to +200°F (-29°C to +93.3°C)

Repeatability	1% Maximum Deviation
Set Point Accuracy	±10%
Set Point Differential	15% Maximum
Switch*	SPDT, 20 VA
Electrical Termination	No. 18 AWG, 24" L., Polymeric Lead Wires

**Note:** Bonnet and shuttle assembly should be removed from unit during welding or brazing. (See bonnet assembly removal under "Maintenance" on back of sheet.)

\*See "Electrical Data" on inside pages

### Dimensions (FS-200 Series)

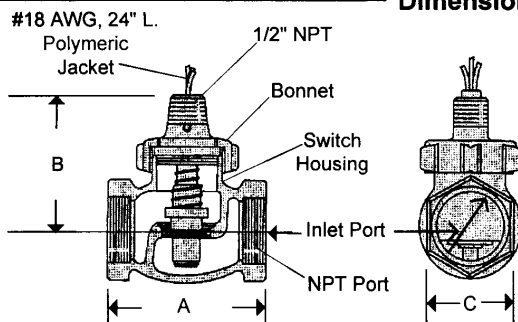

Model	Port Size NPT	"A" Dim.	"B" Dim.	"C" Dim. (HEX)
FS-200 and FS-200 Adjustable	1"	3-1/4"	3"	1-25/32"
	1-1/4"	4"	3-3/16"	2-3/16"
	1-1/2"	4-1/2"	3-1/2"	2-1/2"
	2"	5-3/8"	4"	3-3/32"
	2-1/2"	6-5/16"	4-1/2"	3-5/8"
	3"	7-3/8"	5-5/32"	4-3/8"

Adjustable versions available in 1" port sizes only.



## Specifications (FS-400 Series) . . .

### Wetted Materials

Housing	Bronze
Shuttle	Delrin®
Spring	316 Stainless Steel
O-Ring	Viton®
Other Wetted Parts	Ceramic
<b>Pressure Rating, Max.</b>	
Operating	400 PSI @ 100°F (+37.8°C)
Proof	800 PSI @ 100°F (+37.8°C)
Operating Temperature	-20°F to +180°F (-29°C to +82.2°C)
Repeatability	1% Maximum Deviation
Set Point Accuracy	±10%
Set Point Differential	15% Maximum
Switch*	SPDT, 20 VA
Inlet/Outlet Ports	3/4" NPT
Electrical Termination	No. 18 AWG, 24" L., Polymeric Lead Wires

\*See "Electrical Data" below.



This product is suitable for Class I and Class II applications ~~only~~, per the requirements of standard EN60730 and any additional specific requirements for a particular application or medium being sensed. Class I compliance of metal bodied units requires a ground connection between the metal body and the earthing system of the installation. Class I compliance of plastic bodied units in contact with a conductive medium requires that the medium be effectively earthed so as to provide an earthed barrier between the unit and accessible areas. For Class III compliance, a supply at safety extra-low voltage (SELV) must be provided. Please consult the Factory for compliance information on specific part numbers.

### Electrical Data

#### Switch Ratings - Maximum Resistive Load

VA	Volts	Amps AC	Amps DC
10 General Use	0-50	.2	.13
	120	.08	N.A.
	100	N.A.	.3
20 Pilot Duty	0-30	.4	.3
	120	.17	.13
	240	.08	.06
50 General Use	0-50	0.5	0.5
	120	.4	.4
	240	.2	.2

**Dimensions (FS-400 Series)**

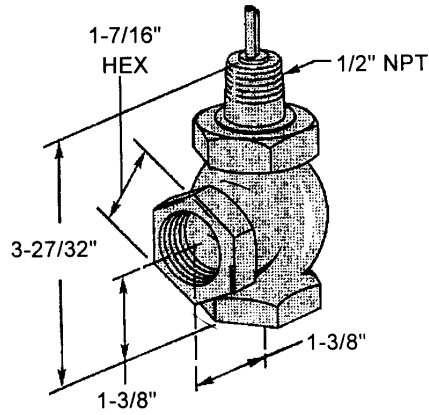

**Pressure Drop Charts - Typical**

**FS-200 Series**

**1" NPT and 1-1/2" NPT Ports**

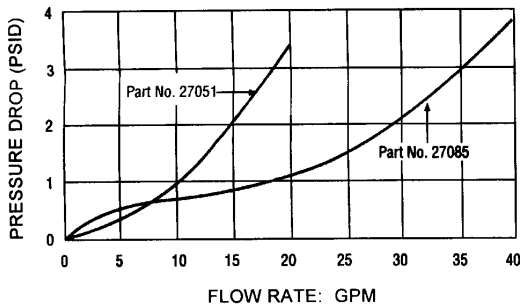

**2" NPT and 3" NPT Ports**

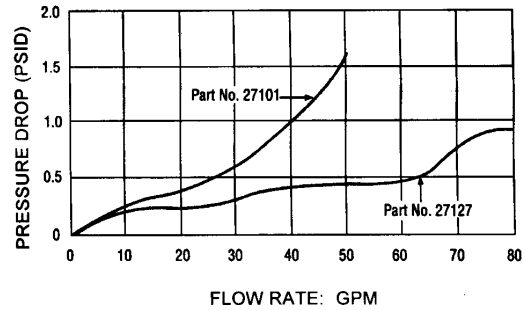

**Note:** Tests conducted with units in horizontal position (lead wires up) with water at +70°F (21°C).

**FS-400 Series**

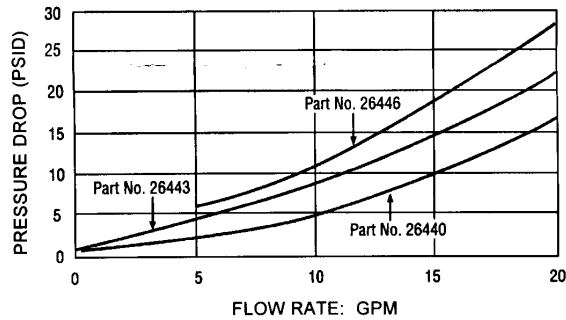

**Note:** Tests conducted with units in vertical position (lead wires up) with water at +70°F (21°C).

**Electrical Connection . . .**

Lead wires and 1/2" NPT or junction box with 1/2" NPT.

**Maintenance . . .**

Occasional cleaning when excessive contamination is present in the liquid is the only maintenance normally required. With system shut-down and no liquid in piping, remove bonnet nut to disassemble unit for cleaning. **It is not necessary to remove unit body from the system.** Remove retainer ring "A" for complete shuttle disassembly. Remove ring "B" to disassemble disc only.

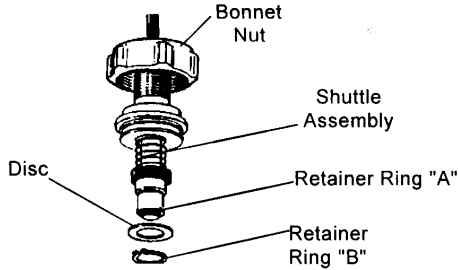

**Flow Setting Adjustment . . .**

*(FS-200/400 Adjustable and FS-400 Units.)*

Standard units are normally supplied with adjustment set at "minimum flow" - adjustment screw slot (and vane within unit) in vertical position, as shown below. Adjustment may be made with unit on test stand or installed in system. With liquid flowing at desired rate, adjust screw in side of housing until unit just actuates. (Switch closes or opens, as desired.)

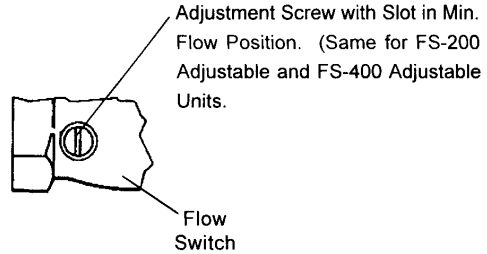

**Typical Wiring Diagram . . .**

**FS-200/400 Series**  
**(Fixed & Adjustable)**

SPDT, Shown Dry

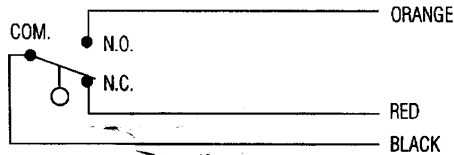

**Important Points!**

Product must be maintained and installed in strict accordance with the National Electrical Code and GEMS technical brochure and instruction bulletin. Failure to observe this warning could result in serious injuries or damages.

An appropriate explosion-proof enclosure or intrinsically safe interface device must be used for hazardous area applications involving such things as (but not limited to) ignitable mixtures, combustible dust and flammable materials.

Pressure and temperature limitations shown on individual catalog pages and drawings for the specified flow switches must not be exceeded. These pressures and temperatures take into consideration possible system surge pressures/temperatures and their frequencies.

Selection of materials for compatibility with the media is critical to the life and operation of GEMS flow switches. Take care in the proper selection of materials of construction; particularly wetted materials.

Life expectancy of switch contacts varies with applications. Contact GEMS if life cycle testing is required.

Ambient temperature changes do affect switch set points, since the specific gravity of a liquid can vary with temperature.

Flow switches have been designed to resist shock and vibration; however, shock and vibration should be minimized.

Liquid media containing particulate and/or debris should be filtered to ensure proper operation of GEMS products.

Electrical entries and mounting points may require liquid/vapor sealing if located in an enclosed tank.

Flow switches must not be field repaired.

Physical damage sustained by the product may render it unserviceable.



**Gems Sensors**  
One Cowles Road  
Plainville, CT  
06062.1198

tel 860.747.3000  
fax 860.747.4244

P/N 45523  
Rev. K