



Coaxial Dynamics

A CDI INDUSTRIES, INC. COMPANY
SPECIALISTS IN RF TEST EQUIPMENT & COMPONENTS

6800 Lake Abram Drive
Middleburg Heights, OH 44130
Telephone: (440) 243-1100
Fax: (440) 243-1101
Web Site: www.coaxial.com
E-mail: support@coaxial.com

Instruction Manual

Model 86715 RF Air-Cooled Coaxial Load



LIMITED WARRANTY

We take pride in manufacturing products of the highest quality and we warrant them to the original purchaser to be free from defects in material and workmanship for the period of one year from date of invoice.

Additionally, products of our manufacture repaired by us are warranted against defects in material and workmanship for a period of 90 days from date of invoice, with the provisions described herein.

Should a product, or a portion of a product of our manufacture prove faulty, in material or workmanship, during the life of this warranty, we hereby obligate ourselves, at our own discretion, to repair or replace such portions of the product as required to remedy such defect. If, in our judgment, such repair or replacement fails to be a satisfactory solution, our limit of obligation shall be no more than full refund of the purchase price.

This warranty is limited to products of our own manufacture. Equipment and components originating from other manufacturers are warranted only to the limits of that manufacturer's warranty to us. Furthermore, we shall not be liable for any injury, loss or damage, direct or consequential, arising out of the use, or misuse (by operation above rated capacities, repairs not made by us, or any misapplication) of the equipment.

Before using, the user shall determine the suitability of the product for the intended use; and the user assumes all risk and liability whatsoever in connection therewith.

The foregoing is the only warranty of Coaxial Dynamics and is in lieu of all other warranties expressed or implied.

Warranty returns shall first be authorized by the Customer Service Department and shall be shipped prepaid.

INTRODUCTION

This manual gives you specific information on the installation, operation and service for the Model 86715 Series Air-Cooled Coaxial Load. Most of the loads are field serviceable, but we recommend their return to us for repair. Mistakes can be costly compared to the low cost for our trained personnel to make the repairs and return the load to new performance specifications. Labor and packaging costs are minimal. We take the load completely apart, clean and inspect all parts, repair/replace as necessary, reassemble, power test, VSWR test and package the load for shipment. If new parts are required in the load (such as resistors etc.), this will be an additional cost. The average turn-around time on repairs is approximately 10 working days and generally will depend on your needs. When sending in repairs, please include: your company name and address, the operating frequency you use, fax number, telephone number and your name in case we need to talk to you about the load or obtain shipping instructions. We can accommodate most shipping methods.

SHIP TO: Coaxial Dynamics
 6800 Lake Abram Drive
 Middleburg Heights, Ohio, USA 44130

For information call: 1-800-COAXIAL (1-800-262-9425)

TABLE OF CONTENTS

MODEL 86715

<u>SECTION</u>	<u>PAGE</u>
Warranty	2
Introduction.....	3
Precautions.....	6
I. Description and Leading Particulars	
1-1 Purpose and Application of Equipment.....	7
1-2 Equipment Supplied	7
1-3 Equipment Required But Not Supplied.....	7
1-4 General Description.....	7
1-5 Electrical Description.....	7
1-6 Mechanical Description.....	8
1-7 General Principle of Operation.....	8
1-8 Operating and Adjustment Controls.....	8
II. Test Equipment and Special Tools	
2-1 Test Equipment Required.....	9
2-2 Special Tools Required.....	9
III. Preparation for Use and Reshipment	
3-1 Unpacking Equipment.....	10
3-2 Pre-Installation Inspection.....	10
3-3 Pre-installation Test.....	10
3-4 Installation	10
3-5 Location.....	10,11
3-6 Mounting	11
3-7 Connections	11
3-8 Ducting.....	11,12
3-9 Adjustments.....	12
3-10 Preparation for Reshipment.....	12
IV. Theory of Operation	
4-1 General.....	13
4-2 Control Circuits	13

TABLE OF CONTENTS (cont'd)

MODEL 86715

<u>SECTION</u>	<u>PAGE</u>
V. Maintenance	
5-1 Cleaning.....	14
5-2 Lubrication	14
5-3 RF Circuit (including resistor replacement).....	14,15
VI. Diagrams	
Outline and Dimensions.....	16
Schematic Diagrams	17-19
Parts List	20
VII. Specifications.....	21
VIII. Illustrations	
Model 86715 RF Coaxial Air-Cooled Load	cover
Vertical Side Panel Displaced.....	22
Access Panels Displaced/Resistor Assembly	23

PRECAUTIONS

CAUTION

Do not block air grills;
blocking air flow can cause unit to fail!

⚡WARNING⚡

Do not attempt any service or parts replacement without first disconnecting all AC power and RF power. Failure to do so may result in serious or *fatal electrical shock*.

CAUTION

Do not apply more than rated power to unit. Damage will occur before thermal protectors can activate interlock circuit if large overloads are applied.

☠CAUTION☠

When using any cleaning solvents or solutions, assure that there is adequate ventilation to protect personnel from breathing any irritable or possibly toxic fumes.

OPERATING TEMPERATURE WARNING

CARE SHOULD BE TAKEN TO OPERATE UNIT BELOW STATED
MAXIMUM AMBIENT OPERATING TEMPERATURE.

OPERATION ABOVE RATED AMBIENT
TEMPERATURE MAY CAUSE MOTOR THERMAL
PROTECTION TO SHUT OFF FAN, WHICH MAY
CAUSE DAMAGE TO UNIT.

PROVISIONS ARE MADE TO TRIP THE INTERLOCK
IN THE EVENT OF OVERHEAT, BUT THE INTERLOCK
MUST BE PROPERLY CONNECTED TO THE RF SOURCE
FOR THIS FUNCTION TO OPERATE.

NEVER OPERATE WITH INTERLOCK
DISCONNECTED OR MALFUNCTIONING.

SECTION I

DESCRIPTION AND LEADING PARTICULARS

1-1. Purpose and Application of Equipment. The Model 86715 Air-Cooled Coaxial Load is designed to safely dissipate a maximum of 15,000 watts of electrical energy over a frequency range of DC to 240 Mhz.

1-2. Equipment Supplied. The Model 86715 Coaxial Load is supplied with standard RF connectors. Their designations are:

1 5/8 EIA Swivel flange:	Model 86715-1
1 5/8 Unflanged recessed:	Model 86715-2
1 5/8 Unflanged flush:	Model 86715-3

The standard power supply voltages are:

-110:	110-120VAC, single phase, 60 Hz
-230:	208-230VAC, single phase, 50/60 Hz
-380:	380VAC, single phase, 50 Hz

1-3. Equipment Required But Not Supplied. The Model 86715 Coaxial Load is complete as supplied, but the user must furnish AC Mains input, RF input, interlock control cable and ground cable appropriate to each installation.

1-4. General Description. The Model 86715 Coaxial Load is enclosed in a single aluminum case which is painted with a durable acrylic finish. Power connection is made through a multi-contact IEC style connector on the rear panel of the enclosure. This panel also contains a 4-screw barrier terminal strip for connection of the interlock circuit and a 1/4-20 UNC-2B stud for attachment of the ground. The RF connector is located in the center of the top panel.

1-5. Electrical Description. The Model 86715 contains a 50 ohm non-reactive resistor assembly capable of dissipating 15,000 watts of applied electrical energy at sea level at frequencies between DC and 240 Mhz with a maximum VSWR of 1.15 to 1. No provisions are made for tuning the resistor assembly and all operating controls relate to the operation of the blower assembly. The blower control circuit consists of three switches wired in parallel to control the blower motor contactor. Power is supplied to this contactor and to the "Blower On" lamp whenever the equipment is attached to the correct power supply and the main power switch is "ON" or when one of the fan thermostats senses a temperature equal to or greater than 120° ($\pm 7^\circ$) F. The transmitter interlock circuit consists of two thermal switches wired in series to control the interlock relay. Power is supplied to this relay whenever the equipment is attached to the correct power supply and neither of the overtemperature thermal switches senses a temperature equal to or greater than 250° ($\pm 7^\circ$) F. A lamp is provided to indicate when one or more of the overtemperature switches opens. It is labeled "OVERHEAT", indicating a change in state of the interlock.

SECTION I (cont'd)

DESCRIPTION AND LEADING PARTICULARS

- 1-6. Mechanical Description.** The Model 86715 RF Coaxial Load is a 50 ohm non-reactive resistor assembly which is cooled by forced ambient air. The blower assembly is a 1/3 HP direct-drive centrifugal blower. The blower moves air from floor level into a closed plenum surrounding the resistor assembly. Air then enters the resistor assembly and flows downward through it to the transition duct and then out of the enclosure via the discharge grill. This places the RF input connector at the coolest point in the air stream and affords exceptionally quiet operation.
- 1-7. General Principle of Operation.** After ascertaining that the Model 86715 is connected to the correct power supply, connect the transmitter interlock circuit and RF source. Turn the main power switch "ON" to start the fan and enable transmitter. Operate transmitter as desired. To stop operation, it is necessary to first turn off the transmitter, then the main power switch on the Model 86715. The fan may continue to run for some time. This depends upon the power level at which the load was operating and upon the ambient air temperature. This feature is necessary to prevent damage to the load. The Model 86715 can be operated in a "Standby" or "Reject" mode with the blower off. Current draw in this mode is 60 milliamperes. To operate in this mode, connect the unit as before and leave the main power switch on the front panel "Off". It is highly recommended that the normally open pair on the interlock terminal board be used to control a user-supplied alarm circuit. This pair will close on power failure or overheat, and the alarm, if independent of the AC power supply for the unit, will notify the operator of a fault.
- 1-8. Operating and Adjustment Controls.** The only operating control is the main power switch. No field adjustments are necessary or possible.

SECTION II

TEST EQUIPMENT AND SPECIAL TOOLS

2-1. Test Equipment Required. No test equipment is required for routine maintenance. In some circumstances it may be desirable to determine the temperature differential (outlet air minus inlet air) and ambient air temperature which the equipment is experiencing. We recommend the John B. Fluke Mfg. Co. Model 52 or equivalent instrument for this function.

2-2. Special Tools Required. Although no non-standard tools are required for routine maintenance, we recommend the technician have the following specialized tools available:

1 Torx T-15 driver

1 Tee handle hex key, 7/32" bit

1 Power screwdriver with 7/32" hex key & torx T-15 bit

SECTION III

PREPARATION FOR USE AND RESHIPMENT

3-1. Unpacking Equipment. The units should be handled and unpacked with care. Inspect outer cartons for evidence of damage during shipment. *Claims for damage in shipment must be filed promptly with the transportation company involved.* No internal packaging or bracing is used for shipments and the units should not rattle when being unpacked.

3-2. Pre-installation Inspection. Conduct a thorough inspection of the units, paying particular attention to the following items:

- Screws in place and tight.
- All panels and grills free of dents and scratches.
- AC input receptacle visually OK.
- Interlock terminal strip visually OK.
- RF connector visually OK.

While inspecting RF connector, measure DC resistance of the unit by reading from the center conductor to the outer conductor. Compare this reading to that on the specification sheet at the end of this manual. Reading should be ± 1 ohm. If not, consult factory.

3-3. Pre-installation Tests. Prior to installation, connect the load to AC Mains power for the following tests:

- a. Read data plate on lower rear panel of resistor enclosure and connect to a suitable source of AC power.
- b. Turn main switch on and check for quiet blower operation.
- c. Connect an ohmmeter or a battery operated test lamp across the normally closed terminal pair on the interlock terminal board.
- d. Turn the main power switch off, observing the indicator (ohmmeter or test lamp). It should remain as it was.
- e. Now disconnect the AC power from the unit. The indicator should change state (terminals open).

3-4. Installation. The Model 86715 must be installed in a location convenient for servicing. Consideration should be given to adequate accessibility for maintenance and unit replacement. No attempt is made in this handbook to present complete installation instructions, since physical differences in plant will determine the installation procedure. General guidelines are outlined in subsequent paragraphs.

3-5. Location. The location selected for the Model 86715 should be dry, free of excessive dust and have an ambient temperature below 110°F (40°C). The room should be well ventilated to prevent excessive temperature rise and consequent derating of the unit. The maximum dissipation of the unit is 15,000 watts. This is equal to 51,195 Btu/hr., which may be ducted out of the building envelope.

SECTION III (cont'd)

PREPARATION FOR USE AND RESHIPMENT

The unit should be oriented to provide a short, direct duct run in order to avoid high static pressure and loss of cooling efficiency. The assistance of a competent heating and air conditioning installer will help avoid over-or-under-specifying the duct system.

- 3-6. Mounting.** The Model 86715 is designed to be floor-mounted and may be securely attached to the floor. The enclosure rests on four fixed aluminum feet. These are tapped for 3/8-16 machine screws.

CAUTION!

THE UNIT SHOULD BE ATTACHED TO THE PROPER AC POWER SUPPLY WITH INTERLOCK CONNECTED WHENEVER THE RF CONNECTOR IS ATTACHED TO THE SOURCE. INADVERTENT APPLICATION OF RF POWER TO THE UNIT WITHOUT AC POWER MAY DAMAGE OR DESTROY THE RESISTOR ASSEMBLY.

- 3-7. Connections.** There are three connectors on the Model 86715: the RF connector (1 5/8 inch EIA swivel flange or unflanged), the AC power supply and the transmitter interlock.
- a. The RF connector is on the top panel of the unit. Connect to the appropriate RF line from the transmitter.
 - b. The AC power supply connector is an IEC style female power connector located on the rear panel of the enclosure.
 - c. The transmitter interlock is attached to the normally closed terminals of the 4-position terminal strip located on the rear panel of the enclosure. The terminals are closed whenever AC power is supplied to the unit and no overheat condition exists. The normally open terminals are isolated from the normally closed terminals and are provided for an alarm circuit for reject (standby) mode operation or remote installations.
- 3-8. Ducting.** In many installations it will be necessary to duct the discharge air from the Model 86715 to the exterior of the building. In some installations it will also be necessary to supply inlet air from outside of the climate controlled portion of the building.

The discharge air flow is approximately 325 SCFM at a maximum temperature of 250°F. Due to the high temperatures involved, non-metallic duct materials should not be used. Attaching a discharge duct to the unit is easily accomplished:

1. Remove the 10 torx head screws attaching the discharge grill.
2. Then, replace the discharge grill with a discharge air duct adapter.

SECTION III (cont'd)

PREPARATION FOR USE AND RESHIPMENT

Suitable ducting can then be attached to the adapter. This duct should be as short as possible to minimize back pressure. Design of the ducting and wall or ceiling penetrations should be referred to a competent heating and air conditioning firm.

"Make-up air" is a ventilation term used to indicate the supply of outdoor replacement air to a building in a controlled manner. It may be provided for the Model 86715 by ducting into the room or by extending a supply duct to either intake grill of the blower enclosure and installing a blanking plate on the other grill.

Make-up air will enter the building to equal the volume actually exhausted, whether or not provision is made for this replacement. However, the actual exhausted volume may not equal the design volume unless an adequate supply is provided.

3-9. Adjustments. No field adjustments are necessary or possible.

3-10. Preparation for Reshipment. No special measures are required to prepare the Model 86715 for reshipment. Care must be taken to protect the RF connector and to immobilize the swivel flange. Packaging should provide protection against abrasion and impact. Special containers are available from the factory. Please inquire.

SECTION IV

THEORY OF OPERATION

- 4-1. **General.** The Model 86715 contains a 50 ohm non-reactive resistor assembly (10 @ 500 ohms) which is cooled by forced air supplied by a centrifugal blower assembly. Control of the blower and of the transmitter interlock circuit is accomplished with a single rocker switch and five thermal switches.
- 4-2. **Control Circuits.** There are 2 control circuits in the Model 86715. One circuit controls the blower, and the other controls the transmitter interlock circuit.

The blower control circuit derives its power from the 26VAC control transformer. Two thermal switches and one rocker switch are connected to AC Control Line 1. Both thermal switches are SPNO and connect to contactor terminal 1, as does the SPST rocker switch. Contactor terminal 3 connects to AC Control Line 2. The blower indicator is connected in parallel with the contactor coil.

The transmitter interlock circuit also derives its power from the 26VAC control transformer. Two SPNC thermal switches are connected in series from Control Line 1 to interlock relay terminal C1. The overheat lamp is connected from Line 1 to interlock relay terminal C1. Interlock relay terminal C2 is connected to Control Line 2.

Interlock relay terminals 1 & 2 are paralleled and are connected to TB1-4. Interlock relay terminals 9 & 10 are paralleled and are connected to TB1-3. This terminal pair is normally open when AC power is supplied to the unit. Interlock relay terminals 3 & 4 are paralleled and are connected to TB1-3. Interlock relay terminals 7 & 8 are paralleled and are connected to TB1-1. This terminal pair is normally open when AC power is supplied to the unit.

SECTION V

MAINTENANCE

WARNING!!

BEFORE PERFORMING ANY MAINTENANCE:

- 1. DISCONNECT POWER AND ALLOW MOTOR TO COME TO A FULL STOP.**
- 2. DISCONNECT RF CONNECTOR ASSEMBLY AND LOCK OUT TRANSMITTER OPERATING CONTROLS.**
- 3. DISCONNECT TRANSMITTER INTERLOCK LINE.**

***FAILURE TO FOLLOW THESE DIRECTIONS
MAY CAUSE FATAL ELECTRICAL SHOCK!***

5-1. Cleaning. The enclosure of the Model 86715 is finished with an acrylic finish or other durable coating system. It should be cleaned with a neutral plastic and glass cleaner such as Windex or Glass Plus. The RF connector should be cleaned with a non-residue contact cleaner such as Miller-Stephenson MS-171/CO₂. Remove dirt accumulations from the fan and motor by vacuuming. Do not use solvents or an air jet, as these can damage the motor. Remove dirt and dust accumulations from the grills and resistor assembly with an air jet and a soft brush.

5-2. Lubrication. Lubricate motor with 10-30 drops of SAE 30 motor oil applied to each bearing oil tube annually.

5-3. RF Circuit. The RF circuit does not require any periodic maintenance and the only repairs possible are the replacement of parts in the connector, quick-step or support portions of the resistor assembly or the replacement of resistors.

To replace resistors it is necessary to remove the panels as follows:

1. Remove the 8-32 X 1/2" torx head screws holding the upper rear panel and set this panel aside.
2. Remove the 8/32 X 1/2" torx head screws which attach the discharge grill and set the grill aside.
3. Remove screws from the vertical sides of the exposed inner panel, then the one 8-32 X 1/2 torx head screw at the bottom. This screw has a lock nut on it which will have to be accessed through the discharge.

SECTION V (cont'd)

MAINTENANCE

4. Remove the two 1/4-20 X 2 hex head cap screws at the bottom. These have lock nuts on them which will have to be accessed through the discharge.
5. Next remove three 8-32 1/2 torx head screws from top of unit. You can now remove panel by bowing it out. With this panel removed, you will have access to the resistor bank.

It is usually not necessary to remove any other panels, but you may find it easier to fit some resistors if you remove the opposite inner panel.

Reverse procedure to reinstall.

CAUTION!

When installing nuts on the 1/4-20 X 2 screws, take care not to overtighten them and fracture the resistors. The resistors are hard, brittle ceramic material. It is very important to avoid impact and excessive force when installing or removing them.

SECTION VI

OUTLINE AND DIMENSIONS

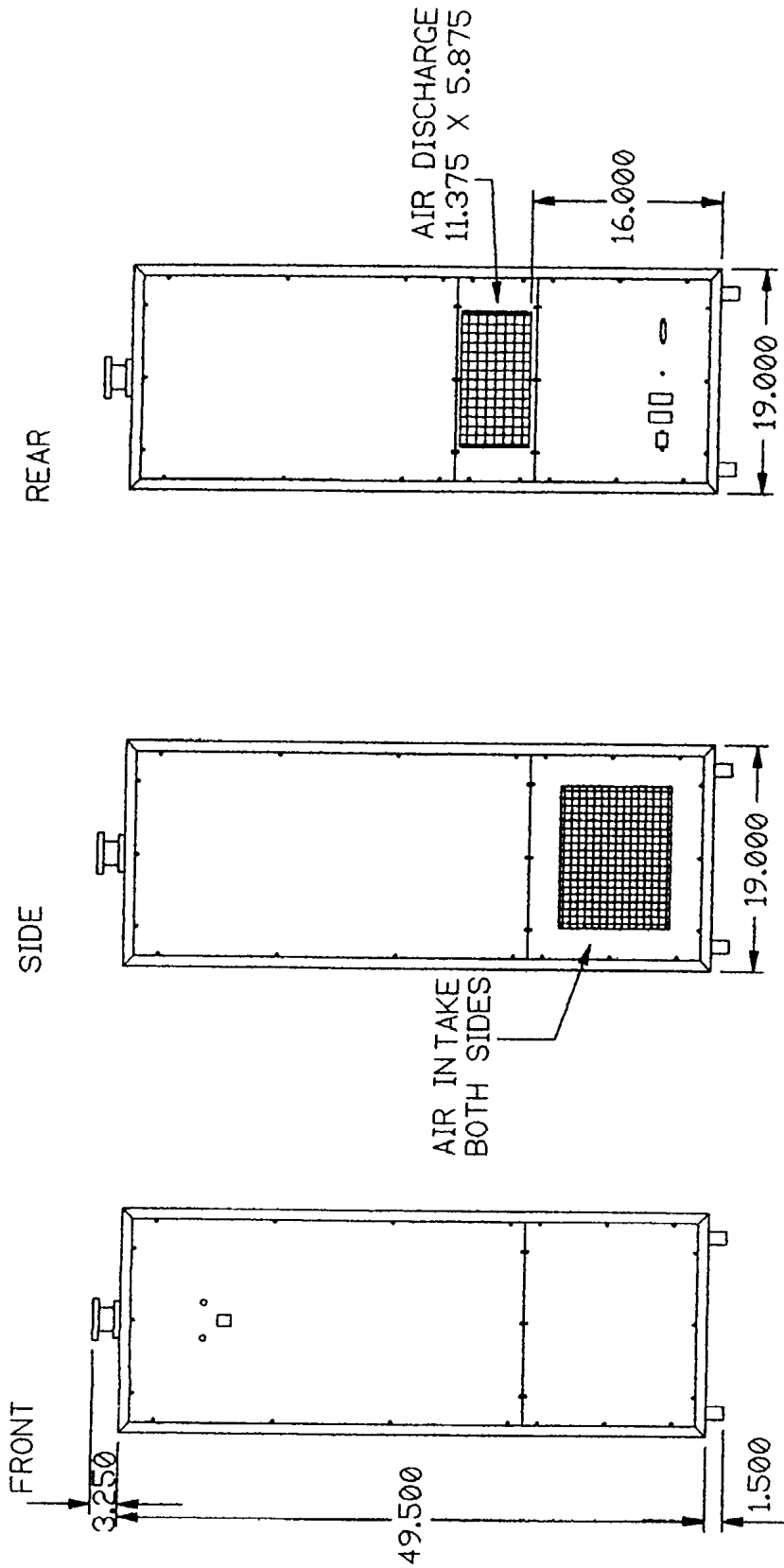

SECTION VI (cont'd)

SCHEMATIC DIAGRAMS

Model 86705 – 86735 with optional Differential Pressure Switch and Remote Activation

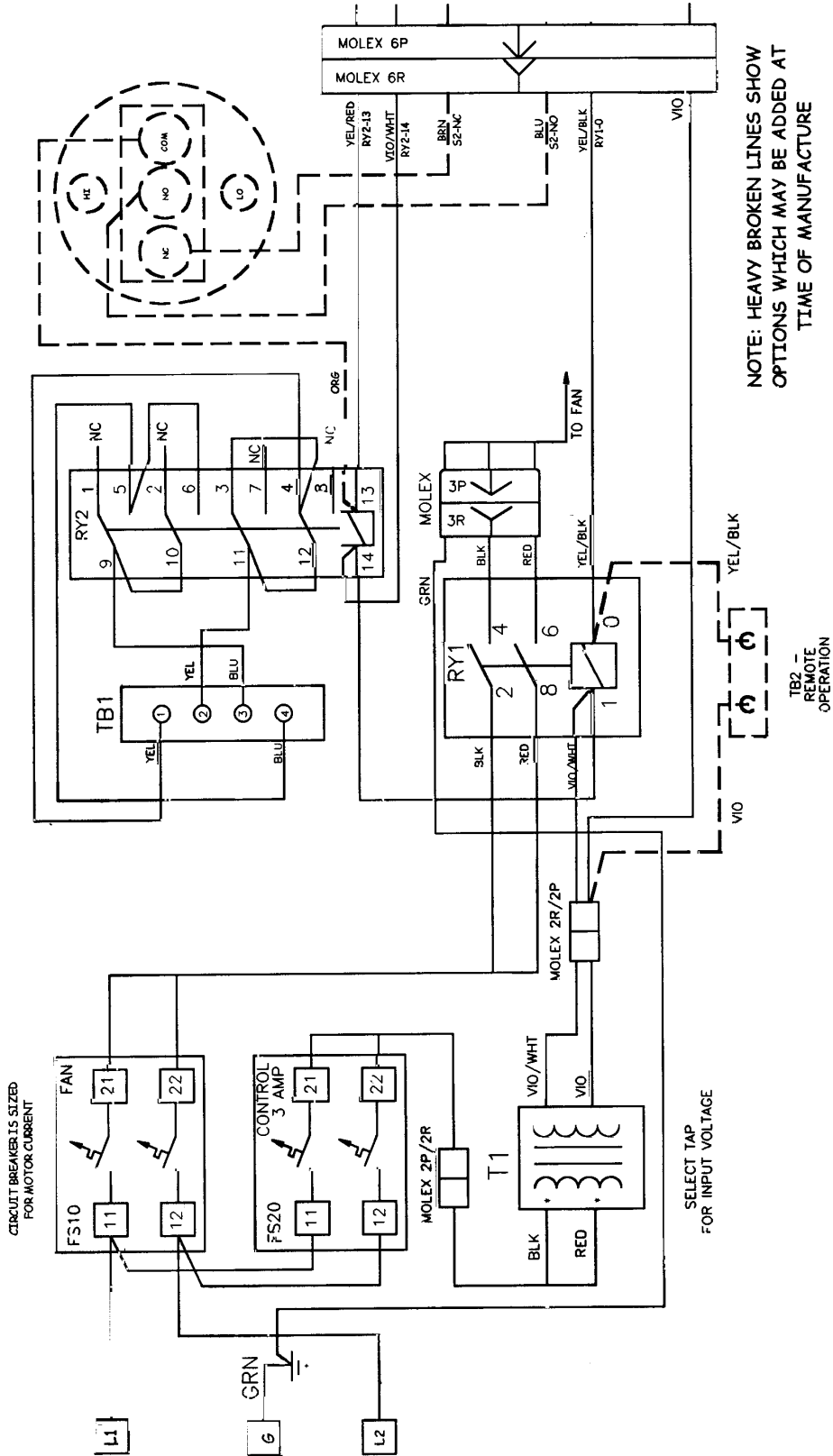

SECTION VI (cont'd)

SCHEMATIC DIAGRAMS Model 86705 – 86775 with optional Differential Pressure Switch and Remote Activation

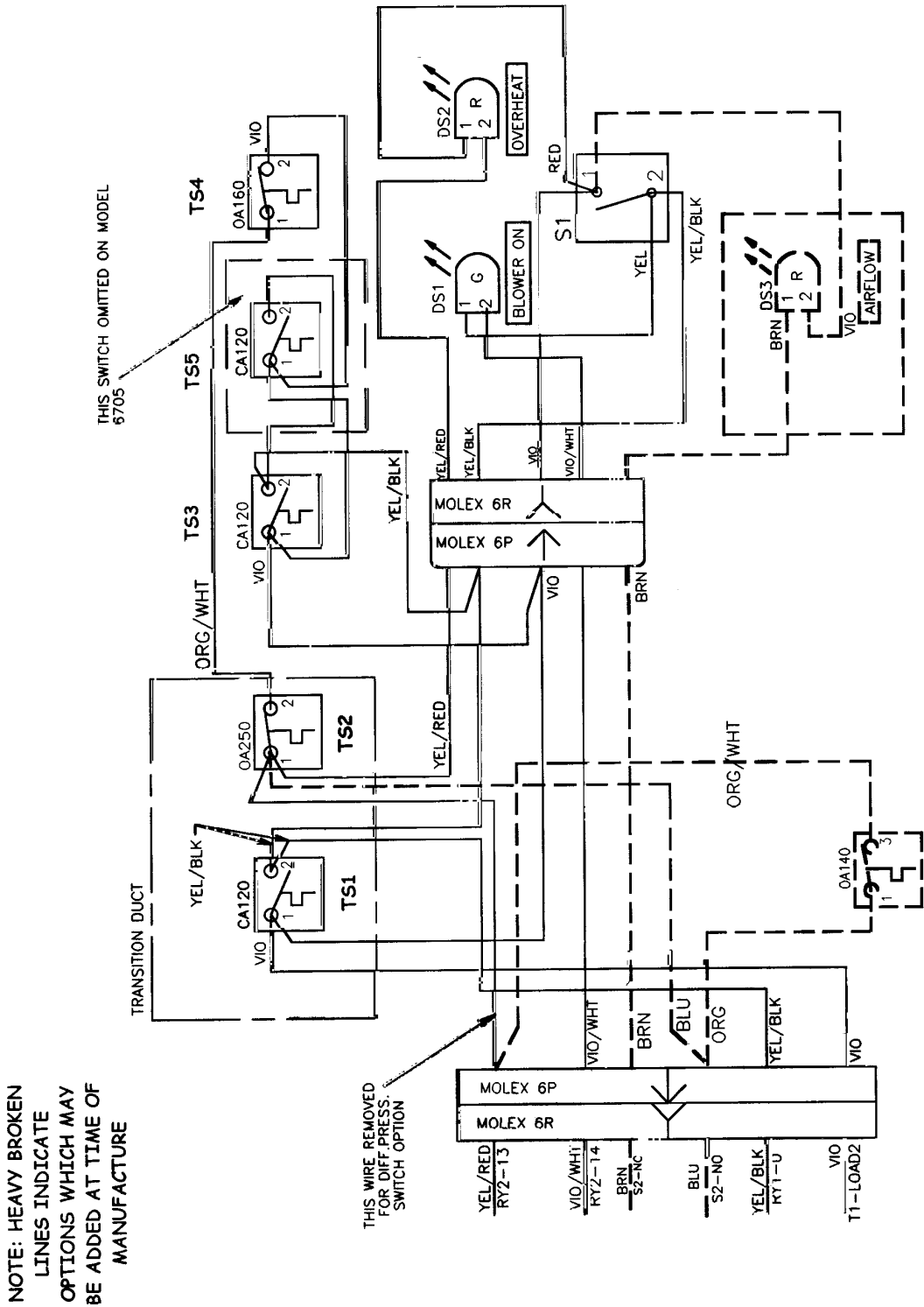

SECTION VI (cont'd)

SCHEMATIC DIAGRAMS

Model 86710 – 86735 with optional Differential Pressure Switch and Remote Activation
(380V – 460V 3 Phase 50 - 60Hz)

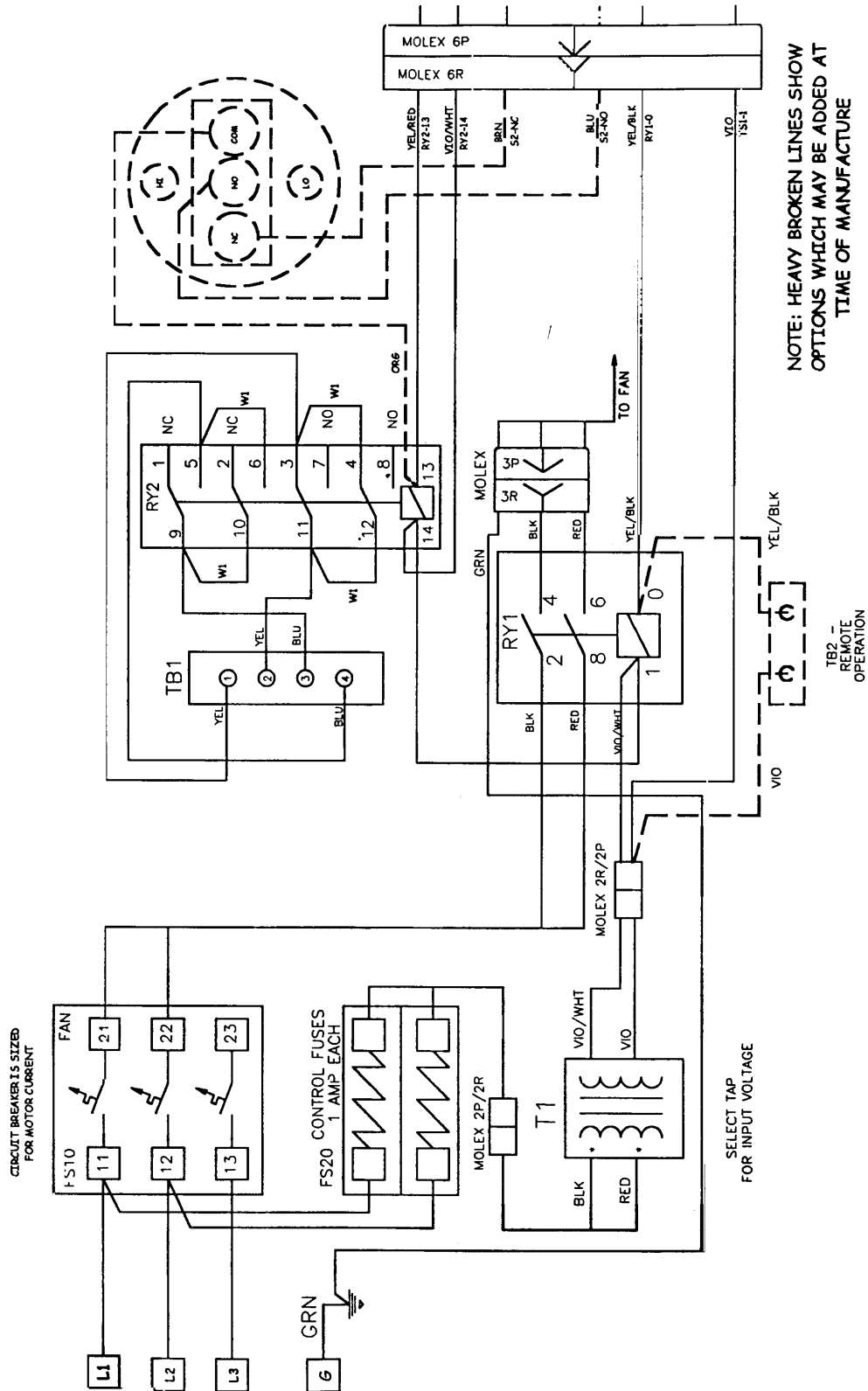

SECTION VI (cont'd)

REPLACEMENT PARTS LIST MODEL 86715

Quantity	Description / Manufacturer Code	Re-Order No.
10	RESISTOR PFS18-501CPK	091-06715-000
1	RELAY, OMRON 24V G7L-2ATUBJ-CB-AC24	161-3A354-000
1	RELAY SOCKET INTRLK 7A-MT14-PC/27E894	304-10000-000
1	CIRC BRKR 3.0A 2-P ETA 3120F323P7T1RS04	304-10000-022
1	CIRC BRKR 5.0A 2-P ETA 3120F323P7T1R04D	304-10000-025
1	BLOCK, TERMINAL 4 PIN, BEAU 72204 NWRK14F2019	304-10000-050
1	LAMP, GREEN 24V 1091QMX5	304-10000-116
1	LAMP, RED 24V 1091QMX1	304-10000-117
1	RELAT INTRLK 25V50/60 BRMFLD KHUA-17A1624	339-10000-001
1	SPRING, INTRLK P&B20C297 TO 304-000	339-10000-005
1	SWITCH, ON/OFF C222-J1-3S205PQF	339-10000-041
1	TRANSFORMER, JARD 5041C 50VA	354-5041C-000
3	SWITCH, THERM CA120F INT01-F-2747	405-10000-057
1	SWITCH, THERM OA250F	413-10000-058
1	SWITCH, THERM OA160F	566-10000-002
For 115 VAC, 60 Hz Only		
1	BLOWER MTR 9.5" 115V 992CFM-DAYTON	161-5C090-000
For 208-230 VAC, 50/60 Hz Only		
1	BLOWER MTR 1/3 HP GE 5KCP39JG3318ET	161-3M810-000
Additional Parts for 208-230 VAC, 50/60 Hz		
1	CAPACITOR STRAP AEROVOX 43547 MODIFIED	161-3X684-000
1	CAPACITOR CAP AEROVOX 44603	161-3X685-000
1	CAPACITOR 370V 5-MFD GE 97F5705BX	161-6X653-000

SECTION VII

SPECIFICATIONS

Model 86715

Impedance ----- > 50 ohms nominal

VSWR @ DC to 240Mhz ----- > 1.15:1 max.

Connectors:

Model 86715-1 ----- > 1-5/8" EIA swivel flange

Model 86715-2 ----- > 1-5/8" Unflanged recessed

Model 86715-3 ----- > 1-5/8" Unflanged flush

Power Rating @ Sea Level ----- > 15 KW

Frequency Range ----- > DC to 240 Mhz

Cooling Method ----- > Forced Air Ductable

Ambient Temperature ----- > -30°C to 43°C

Fan Assembly ----- > 1/3 hp direct drive-centrifugal

AC Power Requirements:

115 VAC, 60 Hz, 3 Amp., 1 Phase

230 VAC, 50/60 Hz, 2 Amp., 1 Phase

380 VAC, 50 Hz, 2 Amp., 3 Phase

Finish ----- > Beige Splatter

Serial No. _____ Frequency _____ Resistance _____

Model _____ Inspected by _____ Date _____

SECTION VIII

Model 86715 Vertical Side Panel Displaced



SECTION VIII (cont'd)

Model 86715

Access Panels Displaced / Resistor Assembly

